

# EPSON

## FX850

Page 1

REF	PART	DESC	SPEC	QTY
100	F337551000	LOWER CASE ASSEMBLY INC 115		1
101	F337553010	PRINTER COVER B		1
102	F337552000	PRINTER COVER A		1
103	F337553020	SHEET GUIDE COVER		1
104	F337554000	SHEET GUIDE ASSEMBLY		1
105	F337555010	BASE PLATE		1
106	F337555020	UPPER CASE		1
107	F337555030	SIDE COVER		1
108	F337557010	LOGO PLATE		1
109	F334554020	GROUND PLATE		3
110	F337555040	PAPER TENSION HOLDER		2
111	1002964	KNOB;B		1
112	F330553060	SHIELD PLATE		1
113	F337558020	NOTICE SHEET		1
114	F337555050	CARRIAGE UNIT HOLDER		1
115	F360551020	RUBBER FOOT		4
117	B310204511	C.B.B. SCREW	M3X12	1
118	B310206411	C.B.B. SCREW	M4X12	4
119	B310206419	C.B.B. SCREW	M4X12	2
120	B313306811	C.B.B.(P) SCREW	M4X25	4
121	B302404211	C.P.S.(O) SCREW	M3X6	9
122	B045800115	C.B.(O) SCREW	M4X8	1
123	B045800114	C.B.(O) SCREW	M4X8	2
124	B320204312	C.B.P. SCREW	M3X8	1
125	B040304114	CUP SCREW	M4X12	1
126	B300304311	C.C.S. SCREW	M3X8	2
200	Y461201000	PEGX BOARD UNIT EXC. 4A		1
201	Y461000001	HEAT SINK	M381-010	1
202	Y566004001	HEAT SINK	M395-050	1
204	Y461001001	INSULATOR	M381-020	1
205	Y903005001	TRANSISTOR HOLDER	M903-1080	1
207	B300304711	C.C.S. SCREW	M3X16	3
208	B300304411	C.C.S. SCREW	M3X10	1
301	X502061011	FUSE FOR 120V	125V 2A	1
310	Y566204000	PEBFIL-II BOARD UNIT - EUR	220V/240V	1
310	Y566204300	PEBFIL-II BOARD UNIT (SCANDINAVIA)	220V	1
311	X502063040	FUSE FOR 220/240V	250V 1.25A	1
321	X502061011	FUSE FOR 100V	125V 2A	1
352	Y566506000	POWER TRANSFORMER	240V	1
450	Y461501000	PGPNL PANEL		1
500	Y461590100	PRINTER MECHANISM INC 528-110-114	M-3B10	1
501	F337002000	FRAME (LEFT)		1
502	F334004000	PAPER HOLDING LEVER (LEFT)		1
503	F337004000	FRAME (RIGHT)		1
504	F334005320	PAPER HOLDING LEVER (RIGHT)		1
505	F337056000	CARRIAGE MOTOR	24W	1
507	F334051010	CARRIAGE MOTOR MOUNTING PLATE		1
508	B302404211	C.P.S.(O) SCREW	M3X6	8
509	F337101000	BELT DRIVEN PULLEY ASSEMBLY		1
510	F334102000	RIBBON DRIVE ASSEMBLY		1
512	F334152000	FRICTION/TRACTOR SENSOR		1
513	F337201000	CARRIAGE UNIT INC 551		1
514	F334251000	PLUNGER ASSEMBLY		1
515	1000244	PAPER GUIDE UNIT - INC 516		1
516	F334254000	PAPER END SENSOR		1
517	F334255000	PAPER FEED ROLLER ASSEMBLY		1

# EPSON

## FX850

Page 2

REF	PART	DESC	SPEC	QTY
518	F334256000	PAPER HOLDING ROLLER ASSEMBLY		1
519	F334257010	TRACTOR FRAME		2
520	F334257020	TRACTOR SHAFT		1
521	F334257031	TRACTOR ASSEMBLY (LEFT)	LOCK LEVER = BLACK	1
521	1010272	TRACTOR,LEFT	LOCK LEVER = GRAY	1
522	F334257041	TRACTOR ASSEMBLY (RIGHT)	LOCK LEVER = BLACK	1
522	1010273	TRACTOR,RIGHT	LOCK LEVER = GRAY	1
523	F334257050	PAPER SUPPORT		1
524	F334257060	TRACTOR GEAR		1
526	F334257070	TRACTOR UNIT COVER		1
527	F304101020	SPROCKET GUIDE SHAFT		1
528	F334258000	PAPER TENSION UNIT		1
529	F334259000	PAPER TENSION FRAME (RIGHT)		1
530	F334260000	PAPER TENSION ROLLER SHAFT ASSEMBLY		1
531	F334258020	PAPER TENSION SUPPORT ROLLER SHAFT		1
532	F334258040	PAPER TENSION ROLLER TRANSMISSION GEAR		1
533	F334258060	PAPER TENSION SUPPROT ROLLER		6
534	F334258070	PAPER TENSION UNIT COVER		1
535	F334258080	PAPER TENSION LOCK LEVER		2
536	F334259010	PAPER TENSION FRAME (LEFT)		1
537	B230250230	PRINT WHEEL SHAFT HOLDER		1
538	F343253010	PAPER GUIDE LABEL		1
539	F334005010	BASE FRAME		1
540	F337005010	CARRIAGE GUIDE SHAFT B		1
541	F334005030	HEAD ADJUSTMENT LEVER		1
542	F337005020	HEAD CABLE		1
544	F334005060	HEAD ADJUSTMENT BUSH		1
545	F334005070	PARALLEL ADJUSTMENT BUSH		1
546	F337005030	HEAD CABLE HOLDER		1
547	F334005090	HOME POSITION SENSOR CABLE		1
548	F334005100	DAMPER		4
549	F334005110	DAMPER SPACER		4
550	F334005120	TRANSPORT LOCKING BRACKET		2
551	F337005040	HEAD CABLE GUIDE		1
552	F334005140	OIL PAD		1
553	F337005050	RIBBON MASK		1
555	F334005170	TIMING BELT		1
556	F334005180	TIMING BELT TENSION SPRING		1
557	1000248	CARRIAGE MOTOR MOUNTING SCREW		2
558	F334005200	PLATEN COVER		1
559	F334005210	PAPER GUIDE PLATE		1
560	F337005070	PAPER FEED MOTOR		1
561	F334005230	PLATEN SHAFT HOLDER		4
562	F334005240	PLATEN		1
563	F334005250	PLATEN GEAR		1
564	F337005060	PAPER FEED REDUCTION GEAR		1
565	F334005270	TRACTOR REDUCTION GEAR		1
566	F334005280	TRACTOR REDUCTION GEAR SPRING		1
567	F334005290	PAPER RELEASE LEVER		1
568	F334005300	SUB PAPER RELEASE LEVER		1
569	F334005310	PAPER FEED SPRING		3
570	F334005330	PAPER HOLDING LEVER SPRING (LEFT)		1
571	F334005340	PAPER HOLDING LEVER SPRING (RIGHT)		1
572	F315062020	PAPER GUIDE PLATE SPRING	168-410	2
573	F331005060	HOME POSITION SENSOR		1
574	F321018010	CARRIAGE SHAFT A		1





# EPSON FX850

Page 5

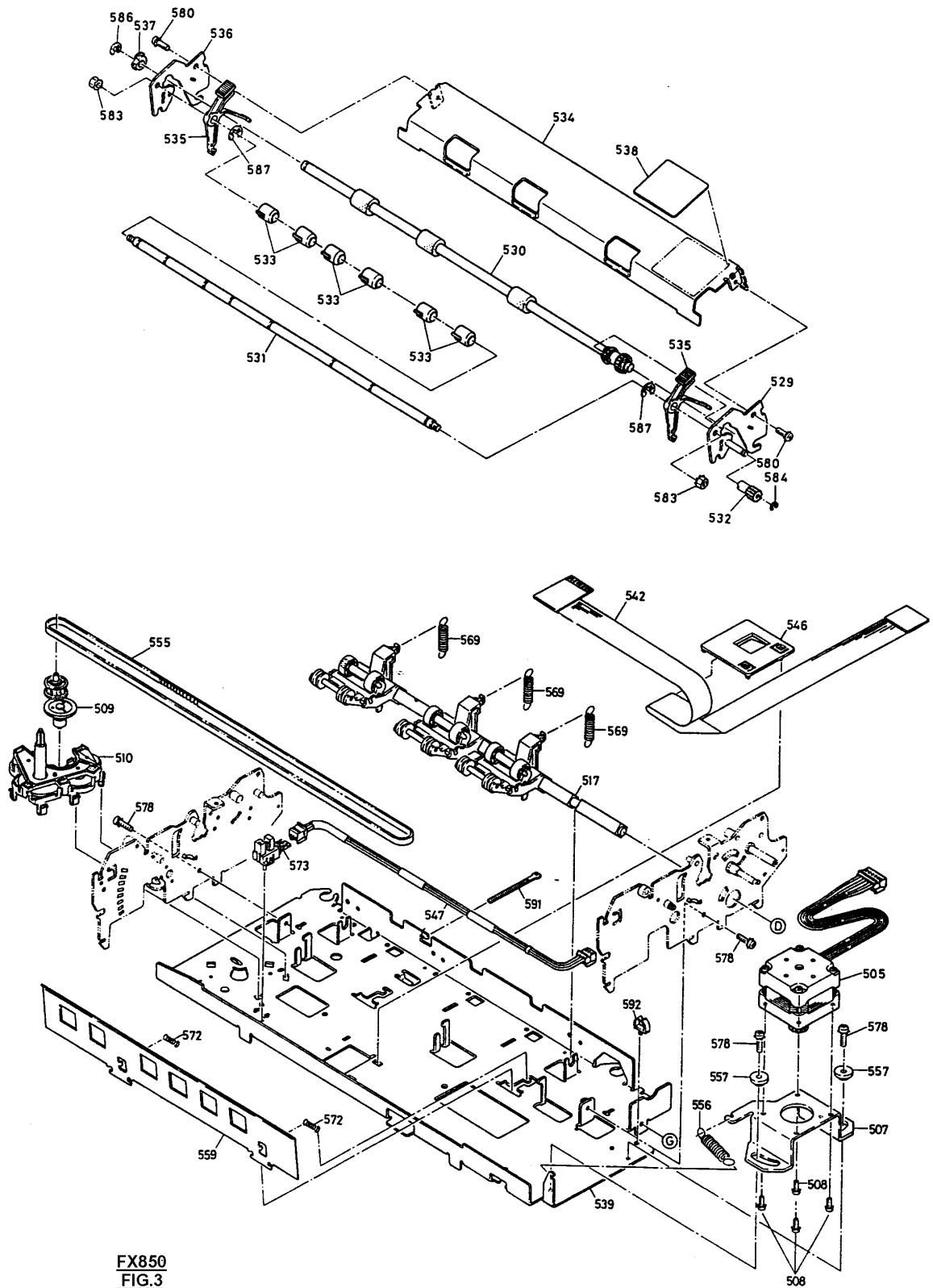

FX850  
FIG.3